

San Patricio Electric Cooperative – (361) 364-2220

**320 amp Pole mounted service with meter rack**

IT IS REQUIRED THAT ALL POLE MOUNTED METER LOOPS BE ON THE WORK SITE ON THE DAY THAT CONSTRUCTION IS SCHEDULED IN ORDER FOR WORK TO BE DONE.

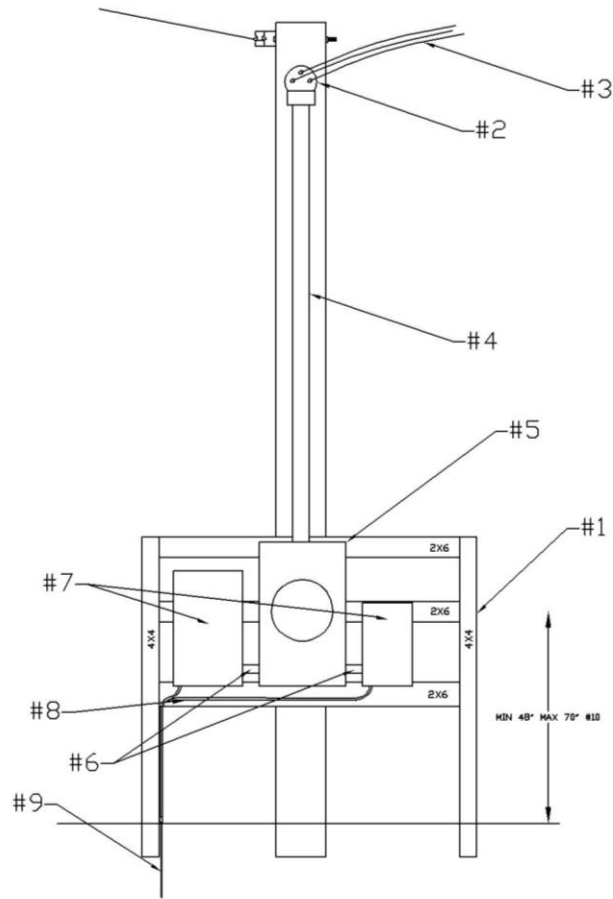

Installed on a **30-ft. meter pole** as provided by San Patricio Electric

**320 Amp Meter Loop**

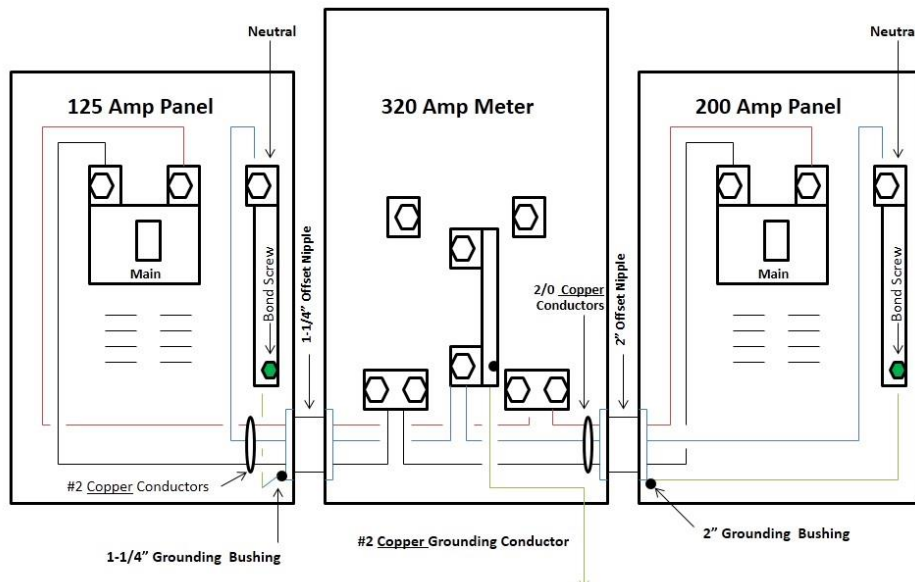

Minimum 5/8" Ground Rod Shall be Below Ground Level

## San Patricio Electric Cooperative – (361) 364-2220

### **320 amp Pole mounted service with meter rack**

1. Build rack to accommodate Meter can and Panel(s) and must be attached to meter pole.
2. 2 ½ - 3” Weather head
3. Mark neutral with white tape or use white colored wire. Wire must extend out of weatherhead at least 24”.
4. 15 feet of 2 ½” - 3” rigid galvanized conduit or rigid aluminum conduit or Schedule 80 Gray PVC pipe.
5. 320 amp Ringless Meter can.
6. PVC TA’s (Treaded Adapters) with lock rings and plastic bushing from Meter enclosure to panel. If threaded galvanized nipple is used, there must be a bonding bushing installed on the panel side with the ground wire passing through the lug. Chase must be same diameter as riser conduit above meter can. Length must be a minimum of 4” but not more than 6”. Lock rings and plastic bushing are required on all nipples and adapters.
7. Breaker panels must have main breaker/fuses. Service disconnects must only add up to 325amps or below. Above 325 amps see Current Transformer (C.T.) meter loop diagram.
8. Ground Wire #6 green stranded/solid up to 150 amp, #4 green up to 225 amp, #2 green up to 320 amp. Ground wire starts in meter enclosure and passes out to ground rod. From the panel the wire must be in PVC conduit
9. 5/8” x 8’ Copper Weld Ground Rod & Clamp shall be fully driven into earth with the top of the rod just below the surface of the ground.
10. Center of Meter must fall between 48” to 72”

San Patricio Electric has a licensed electrician that builds meter loops and offers other services as well. For a price quote please call the Cooperative at [361-364-2220](tel:361-364-2220)

Consumers may set their own meter pole. **NOTE: Contact SPEC about placement of meter pole in relation to transformer pole BEFORE placing meter pole.** The meter pole must be a minimum of 20 feet in length with a 6” top. Pole must be set 5 feet deep in the ground. Meter loop riser must extend to within 18” from top of the pole. Meter loop should be mounted on the rack so that meter is a minimum of 60” from ground level and a maximum of 72” from ground level. A 5/8” X 8’ copper weld ground rod and copper weld ground rod clamp must be installed with #4 green ground for 150 and 200 amp and #6 green ground for 125 amp service

Meter loop must be completely assembled by the member or by an electrician in order to be connected. Co-op employees will not help in the assembling of a meter loop on the job site.

### **CONSTRUCTION of a 3 WIRE METER LOOP**

Meter Loop must be assembled by the member or by an electrician. The Co-op shall determine the acceptability of the meter loop before the connection is made.

Meter Loop shall be made of rigid galvanized conduit or rigid aluminum conduit or Gray PVC. EMT is NOT acceptable. A minimum size of 350 MCM stranded copper is required.

Meter and Main disconnect must be located on the outside area of any structure and must be accessible to the Cooperative. Disconnect must be located directly below the meter. Disconnect must be breakers or fuses. **BLADED DISCONNECT SWITCHES ARE NOT ALLOWED.**

**Mobile Home/Manufactured Home Service Equipment.** The mobile/manufactured home service equipment shall be located adjacent to the mobile/manufactured home and NOT mounted in or on the mobile home. The service equipment shall be located in sight from and not more than 9.0 m (30 ft) from the exterior wall of the home it serves.

***Reduced neutral not allowed.***

### **CONSTRUCTION of 5 WIRE METER LOOP WILL NO LONGER BE ACCEPTED.**

Consumer wiring from the load side of the consumer’s breaker box **can not** be run back up through the meter can and the main meter loop riser. To feed consumer overhead services, a separate riser pipe must be installed from the breaker box to run back up the pole. This riser must **also** have a neutral wire in it. Riser must be electrical grade PVC (Gray), Galvanized rigid pipe or rigid aluminum conduit. The clearance of this riser must also meet height requirements.

## San Patricio Electric Cooperative – (361) 364-2220

### **320 amp Pole mounted service with meter rack**

#### ALLOWABLE AMPERAGE OF AN INSULATED CONDUCTOR

Taken from National Electric Code Manual Table 310-16

Copper wire, type THHN max. Temp. 90° centigrade, 600 volt insulation minimum

WIRE SIZE		CONDUIT SIZE
#2 Cu.	125 amps per wire	1 ¼"
1/0 Cu.	150 amps per wire	1 ½"
2/0 Cu.	200 amps per wire	2"
3/0 Cu.	225 amps per wire	2
350 mcm	320 amps per wire	2 ½ - 3"

**Aluminum Wire Not Allowed**

#### **Ground Clearance**

The guidelines on ground clearances for service conductors as described on the reverse side **MUST BE FOLLOWED**.

NOTE: For 120/240-volt service drop installations, minimum clearances must be maintained according to SPEC regulations:

12' of clearance should be maintained where no traffic is present

15' of clearance should be maintained over driveways

22' of clearance should be maintained over roadways

22.5' of clearance should be maintained over swimming pools

3.5' of clearance should be maintained over building roofs (no pedestrians)

11' of clearance should be maintained over building roofs (with pedestrians)

The measurement for clearance is determined at the lowest point in the service wire. The clearances from the ground to the service wire will decrease as the distance between the meter pole and the service pole, or transformer pole, increases.

